

**LIUGONG**

# 2100H

3-SERIES FORK TRUCK

ENGINE  
Cummins

RATED POWER  
120.7 hp  
(90 kW)

CAPACITY  
22,046 lb  
(10,000 kg)



# SPECIFICATIONS

EXCLUSIVELY FOR DEALER

## GENERAL

Model	CLG2100H		
Power type	1	Diesel	
Operator type	2	Sit-Down Rider	
Base capacity	3	@ rated load center	22,046 lb (10,000 kg)
Load center	4	24 in (600 mm)	

## WEIGHTS

Service weight	5	unloaded	27,558 lb (12,500 kg)
Axle load	6	loaded/unloaded, front	44,423/12,059 lb (20,150/5,470 kg)
	7	loaded/unloaded, rear	5,181/15,498 lb (2,350/7,030 kg)

## TIRES

Tire type	8	Pneumatic	
Wheels	9	front/rear	4/2
Wheelbase	10	110.2 in (2,800 mm)	
Tire size	11	front	9.00-20-14PR
	12	rear	9.00-20-14PR
Tread width	13	front/rear	63/67.7 in (1,600/1,720mm)

## MAST

Max. fork height	14	with std 2-stage mast	118.1 in (3,000 mm)
Free lift	15	with std 2-stage mast	7.9 in (200 mm)
Height, upright lowered	16	with std 2-stage mast	110.3 in (2,801 mm)
Height, upright extended	17	with std 2-stage mast	172.7 in (4,386 mm)
Mast tilt, fwd, back	18	with std 2-stage mast	6°/12°
Carriage	19	width	87.0 in (2,210 mm)
Fork spread	20	minimum/maximum	16.1/83.9 in (410/2,130 mm)
Fork dimensions	21	T x W x L	3.1 x 6.9 x 59.8 in (80 x 175 x 1520 mm)

## CHASSIS

Length to fork face	22	with std 2-stage mast	167.7 in (4,260 mm)
Overall width	23	87.0 in (2,210 mm)	
Overhead guard height	24	103.1 in (2,620 mm)	
Turning radius	25	minimum outside	148 in (3,760 mm)
Fork overhang	26	with std 2-stage mast	159.8 in (4,060 mm)
Right angle stack	27	add load length and clearance	32.5 in (825 mm)
Ground clearance	28	minimum loaded	144.3 in (3,665 mm)
	29	center of wheelbase	9.7 in (246 mm)

## PERFORMANCE

Model	CLG2100H		
Travel speed	30	loaded/unloaded	11.8/16.2 mph (300/26 km/h)
Lift speed	31	loaded/unloaded	17.4/66.9 fpm (28/0.34/s)
Lower speed	32	loaded/unloaded	70.9/78.7 fpm (0.36/0.4 m/s)
Max. drawbar pull	33	loaded	59 lb (0.3 kg)
Max. gradeability	34	loaded/unloaded	30%/28%

## SYSTEMS

Brakes	35	service	Foot/hyd
	36	parking	Hand/mech
Engine	37	manufacturer	Cummins
	38	model	F3.8
	39	emission compliance	T4F/Tier V
	40	cylinders	4
	41	displacement	3.8 liter
	42	rated power	120.7 hp (90 kW) 2,200 rpm
Transmission	43	max. torque	369 lb/ft (90 N/m) 1500 rpm
	44	type	Powershift
Hydraulic Pressure	45	speeds, fwd/rev	2/2
	46	system	3,046 psi (210 bar)
	47	attachment	2,103 psi (145 bar)

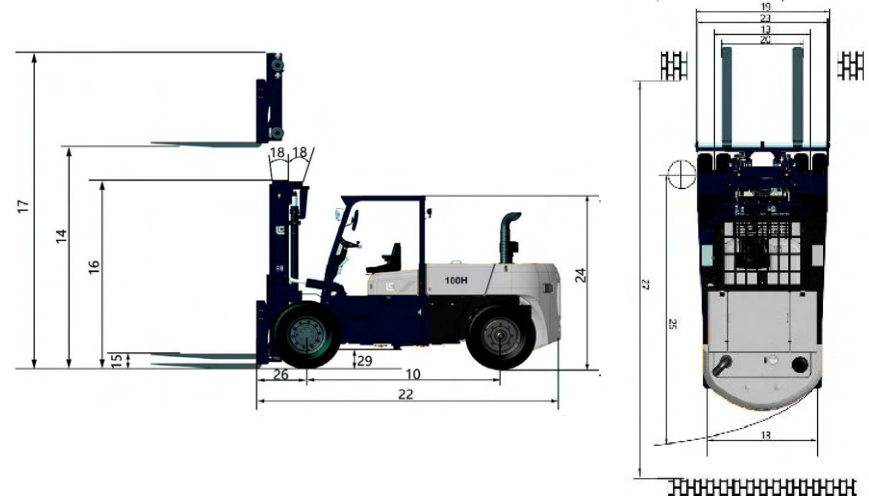

## LGNA-SS-2100H-202304-ENG-US

Specifications and designs are subject to change without notice.  
Machines shown may include optional equipment.

LiuGong Construction Machinery N.A., LLC.  
22220 Merchants Way - Suite 100  
Katy, TX 77449  
USA

T: 281-579-8882  
www.liugongna.com

F: 281-579-8388